

READ AND SAVE THESE INSTRUCTIONS

TAKE 2™ Coffee Maker

USE AND CARE GUIDE FOR
MODEL ME2TMDS



IMPORTANT SAFEGUARDS

When using electrical appliances, basic safety precautions should always be followed, including the following:

- Read all instructions.
- Do not touch hot surfaces. Use handles or knobs.
- To protect against electric shock, do not place cord, plugs, or appliance in water or other liquid.
- Close supervision is necessary when any appliance is used by or near children.
- Unplug from outlet when not in use and before cleaning. Allow to cool before putting on or taking off parts, and before cleaning the appliance.
- Do not operate any appliance with a damaged cord or plug or after the appliance malfunctions, or has been damaged in any manner. Contact Consumer Service for examination, repair or adjustment.
- The use of an accessory not evaluated for use with this appliance may cause injuries.
- Do not use outdoors.
- Do not let cord hang over edge of table or counter, or touch hot surfaces.
- Do not place on or near a hot gas or electric burner, or in a heated oven.
- To disconnect, press the Power Switch with LED Indicator Light so that the light is off, then remove plug from wall outlet.
- Do not use appliance for other than intended use.
- Be certain lids are securely in place before operating appliance.
- Scalding may occur if the lid is removed during the brewing cycles.

SAVE THESE INSTRUCTIONS

THIS PRODUCT IS FOR HOUSEHOLD USE ONLY.

ADDITIONAL IMPORTANT SAFEGUARDS

WARNING: This appliance generates heat and escaping steam during use. Use proper precautions to prevent the risk of burns, fires, or other injury to persons or damage to property.

- All users of this appliance must read and understand this Owner's Manual before operating or cleaning this appliance.
- The cord to this appliance should be plugged into a 120V AC electrical outlet only.
- Use **water only** in this appliance! Do not put any other liquids or food products in this appliance. Do not mix or add anything to the water placed in this appliance, except as instructed in the User Maintenance Instructions to clean the appliance.
- DO NOT attempt to move an appliance containing hot liquids. Allow appliance to cool completely before moving.
- Keep appliance at least 4 inches away from walls or other objects during operation. Do not place any objects on top of appliance while it is operating. Place the appliance on a surface that is resistant to heat.
- If this appliance begins to malfunction during use, immediately unplug the cord. Do not use or attempt to repair the malfunctioning appliance.
- If this appliance falls or accidentally becomes immersed in water or any other liquid, unplug it immediately. **Do not reach into the water! Do not use this appliance after it has fallen into or has become immersed in water.** Contact Consumer Service for examination and repair.
- Do not leave this appliance unattended during use.
- The appliance must be left to cool down sufficiently before adding more water to avoid splattering.
- Always use fresh, cool water in your appliance. Warm water or other liquids, except as listed in cleaning section, may cause damage to the appliance.
- DO NOT lift Filter Basket Lid until brewing is complete, and all parts have cooled.
- The Mugs are designed for use with this appliance. They must never be used on a range top.
- DO NOT put mugs into a microwave.

CAUTION: A short power supply cord is provided to reduce the risk resulting from becoming entangled in or tripping over a longer cord. Do not use an extension cord with this product.

POLARIZED PLUG: This appliance has a polarized plug, (one blade is wider than the other). To reduce the risk of electric shock, this plug is intended to fit in a polarized outlet only one way. If the plug does not fit fully in the outlet, reverse the plug. If it still does not fit, contact a qualified electrician. Do not attempt to modify the plug in any way.

CAUTION: To prevent Plasticizers from migrating from the finish of the countertop or tabletop or other furniture, place **NON-PLASTIC** coasters or placemats between the appliance and the finish of the countertop or tabletop.

Failure to do so may cause the finish to darken, permanent blemishes may occur or stains can appear.

ELECTRIC POWER: If the electric circuit is overloaded with other appliances, your appliance may not operate properly. It should be operated on a separate electrical circuit from other appliances.

WARNING: TO REDUCE THE RISK OF FIRE OR ELECTRIC SHOCK, DO NOT REMOVE THE BOTTOM COVER. NO USER-SERVICABLE PARTS INSIDE. REPAIR SHOULD BE DONE BY AUTHORIZED SERVICE PERSONNEL ONLY.

Before Using Your Take 2™ Programmable Clock Timer Coffee Maker

Before using your Take 2™ Programmable Clock Timer Coffee Maker for the first time, we suggest you become familiar with all of its parts. Read all instructions and cautions carefully.

CAUTION: Press the Power Switch with LED Indicator Light so that the light is off. Unplug from outlet.

IMPORTANT: Never place Thermal Mugs on a hot stove or in a microwave. Never let Thermal Mugs stand in water.

Before brewing coffee, follow instructions for cleaning. See “Care and Cleaning,” page 8.

CAUTION: Do not immerse cord, plug, or coffee maker unit in water or other liquids.

Your product may vary slightly from illustration.

Parts Identification

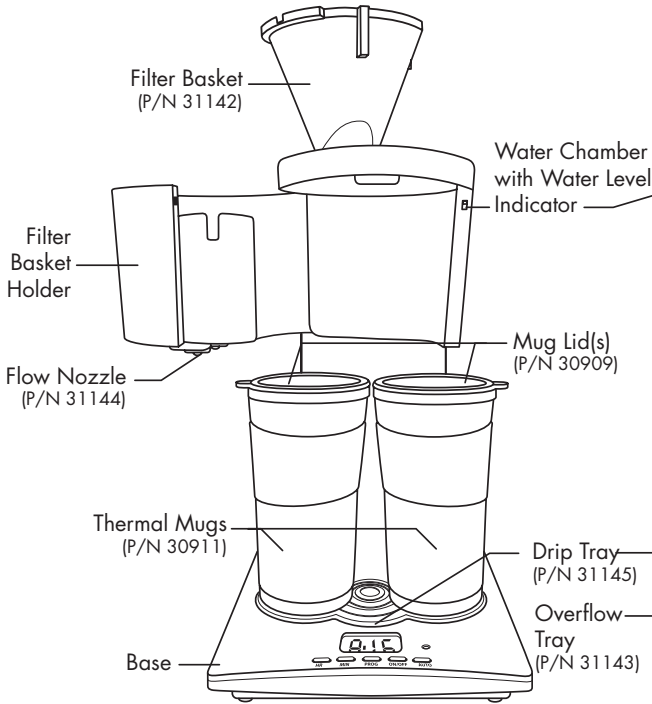

FIGURE A

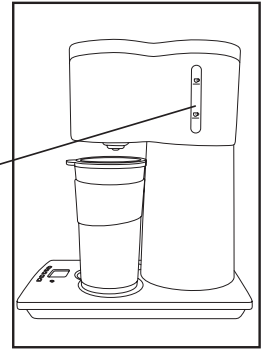

FIGURE B

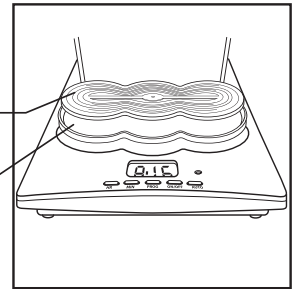

FIGURE C

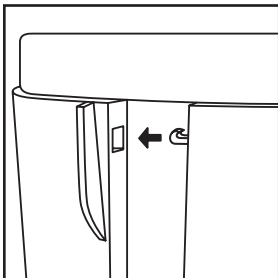

FIGURE D

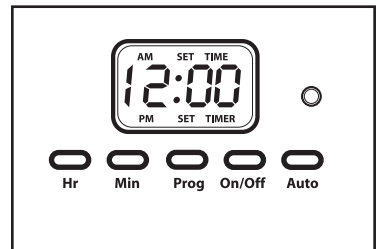

FIGURE E

Setting the Clock

1. Plug into 120 V~60 Hz outlet.
2. The display will go to AM 12:00 and continue to flash until you press a button.
3. Press the Program button, "SET TIME" will be displayed in the top right corner.
4. Press and hold the HR button for rapid hour advancement. When the desired hour is reached, release the button.
5. Press and hold the MIN button for rapid minute advancement. When the desired minute is reached, release the button.
6. Press the PROG button again. The time is now set. If you do not press the PROG button again, the display will automatically return to the time of day after 10 seconds.

Brewing

1. Plug into 120V ~ 60 Hz outlet.
2. Make sure unit is in the OFF position. The LED Indicator Light will be off.
IMPORTANT: Place coffee maker on a level surface.
3. Markings on the Water Level Indicator indicate the amount of water required to brew the desired number of Thermal Mugs. Lift up the hinged Water Chamber Lid and fill to desired level with cold, fresh water for the number of Thermal Mugs (one or two), using the Water Level Indicator on the Water Window.
WARNING: When making one Thermal Mug, do not fill above level 1.
IMPORTANT: If cream or milk will be added to Thermal Mugs, use less water for brewing.
4. For optimal holding temperature, rinse the inside of Thermal Mugs with warm water before brewing. Place Lids securely on tops of Thermal Mugs. Press down on the Lids to ensure proper fit.
NOTE: You can brew either one Thermal Mug or two Thermal Mugs at once. Place Thermal Mugs snugly on Base of unit as shown in Figure A (for two Thermal Mugs). The contoured design on the Base should be used as a guide for Thermal Mug alignment.
5. Insert a #2 paper cone filter into the Removable Filter Basket and add coffee grounds. Use approximately 1½-2 tablespoons for each Thermal Mug of coffee. Close Water Chamber Lid, snapping the Basket into place. (See Figure D.)

6. Press Power Switch ON. The LED Indicator Light will turn red.
CAUTION: Avoid contact with heated water.
IMPORTANT: Do not remove Thermal Mugs until the LED Indicator Light has turned OFF. The LED Indicator Light will turn OFF approximately two minutes after brewing is complete. This delay will allow the last drops of coffee to flow into the Thermal Mugs.
7. After LED Indicator Light turns off, Thermal Mugs may be safely removed.
8. If brewing more than one cycle, allow unit to cool for 10 minutes between cycles.

Helpful Hints for Brewing

- Always use fresh, cold water for brewing. In areas with hard water or where water contains a high mineral content, use cold filtered water for optimal coffee taste.
- For best results, use Melitta® #2 paper cone filters and Melitta® Premium Coffee.
- The markings on the Water Level Indicator reflect the quantity of fresh water to be used. The quantity of brewed coffee is less because the coffee grounds absorb water.

Programming a Delayed Brew

1. Press the PROG button twice, "SET TIMER" will be displayed in the bottom center of the Display Window.
2. Using the HR and MIN button, set the time you wish the coffee to begin brewing. Once the time is set, the display will return to the time of day automatically after 8 seconds, and then "SET TIMER" will disappear. You may also press the PROG button to make the display return to the time of day.
3. Press AUTO button, LED Indicator Light will be green to indicate the timer has been set for delayed start.
Note: To cancel the delayed start, press AUTO once again, the LED Indicator Light will go off and the delayed start program will be cancelled.
4. When the delayed start program has reached the preset time, the LED Indicator Light will change to red and the brewing will start.
Note: During the auto-brew program, you may start brewing at once by pressing the ON/OFF button.

Care and Cleaning

1. Make sure Power Switch is in the OFF position. The LED Indicator Light will be off.
2. Unplug and allow to cool completely before cleaning.
3. Open Filter Basket Holder and lift up on the tab of Filter Basket. Discard any paper filter and coffee grounds.
4. Wash removable Filter Basket, Drip Tray and Overflow Tray, Mugs and Mug Lids in warm, soapy water. Rinse and dry thoroughly. Or, you may wash the Mugs and Lids in the top rack of a dishwasher.
5. Clean the outside of the coffee maker with a damp cloth.
CAUTION: DO NOT IMMERSE CORD, PLUG OR COFFEE MAKER UNIT IN WATER OR OTHER LIQUID.
6. Replace Filter Basket, Drip Tray and Overflow Tray for next use.

Descaling

We recommend that you descale your coffee maker once a month because mineral deposits can form a coating in the coffee maker, causing slower brewing time and possibly an off flavor in the coffee. Use a cleaner recommended for coffee makers. To descale your unit:

1. Pour two ounces of vinegar or coffee cleaner into the Water Chamber. Add cold water to the level 2 indicator.
2. Place a clean #2 paper cone filter in the filter basket and close Water Chamber Lid. Place both Mugs in proper position on Base of unit.
3. Follow "Brewing" instructions (without coffee).
4. When the LED Indicator Light turns off, wait 15 minutes and pour solution from Mugs back into coffee maker. Be sure that the Filter Basket is still in proper position.
5. Turn unit on again. Allow all solution to empty into Mugs. When LED Indicator Light turns off, discard solution.
6. Allow unit to cool 10 minutes. To rinse unit, fill Water Chamber with fresh, cold water up to the level 2 indicator. Insert a fresh paper filter into Filter Basket. Close Water Chamber Lid. Place both Mugs in proper position on Base of unit and turn Power Switch on.
7. At end of cycle, allow unit to cool, discard water and paper filter. Wash and dry Mugs and other removable parts.
8. Unplug coffee maker from outlet. When coffee maker has cooled, wipe exterior with a damp cloth.

IMPORTANT NOTICE

If any parts are missing or defective,

DO NOT return this product.

Please call our Customer Relations Department for assistance.

800-233-9054 Monday - Friday 9am - 5pm CST

LIMITED ONE YEAR WARRANTY

Warranty: This Melitta® product is warranted by Salton, Inc. to be free from defects in materials or workmanship for a period of (1) year from the original purchase date. This product warranty covers only the original consumer purchaser of the product.

Warranty Coverage: This warranty is void if the product has been damaged by accident in shipment, unreasonable use, misuse, neglect, improper service, commercial use, repairs by unauthorized personnel, normal wear and tear, improper assembly, installation or maintenance abuse or other causes not arising out of defects in materials or workmanship. This warranty is effective only if the product is purchased and operated in the USA, and does not extend to any unit which has been used in violation of written instructions furnished with the product, or to units which have been altered or modified, or to damage to products or parts thereof which have had the serial number removed, altered, defaced or rendered illegible.

Implied Warranties: ANY IMPLIED WARRANTIES WHICH THE PURCHASER MAY HAVE ARE LIMITED IN DURATION TO ONE (1) YEAR FROM THE DATE OF PURCHASE. Some states do not allow limitations on how long an implied warranty lasts, so the above limitation may not apply to you.

Warranty Performance: During the above one-year warranty period, a product with a defect will be either repaired or replaced with a reconditioned comparable model (at our option) when the product is returned to the Repair Center, or the purchase price refunded. The repaired or replacement product will be in warranty for the balance of the one-year warranty period and an additional one-month period. No charge will be made for such repair or replacement.

Service and Repair: Should the appliance malfunction, you should first call toll-free 1-800-233-9054 between the hours of 9:00 am and 5:00 pm Central Standard Time and ask for CONSUMER SERVICE stating that you are a consumer with a problem. Please refer to model number ME2TMDS when you call.

In-Warranty Service (USA): For an appliance covered under the warranty period, no charge is made for service or postage. Call for return authorization 1-800-233-9054.

Out-of-Warranty Service: A flat rate charge by model is made for out-of-warranty service. Include \$8.00 (U.S.) for return shipping and handling. We will notify you by mail of the amount of the charge for service and require you to pay in advance for the repair or replacement.

For Products Purchased in the USA, but Used in Canada: You may return the product insured, packaged with sufficient protection, and postage and insurance prepaid to the USA address listed below. Please note that all customs duty / brokerage fees, if any, must be paid by you and we will require you to pay the cost of customs duty / brokerage fees to us in advance of our performing any service.

Risk During Shipment: We cannot assume responsibility for loss or damage during incoming shipment. For your protection, carefully package the product for shipment and insure it with the carrier. Be sure to enclose the following items with your appliance: any accessories related to your problem, your full return address and daytime phone number, a note describing the problem you experienced, a copy of your sales receipt or other proof of purchase to determine warranty status. C.O.D. shipments cannot be accepted.

To return the appliance, ship to:
Attn: Repair Center
Salton, Inc.
708 South Missouri Street
Macon, MO 63552

To contact us, please write, call or email:
Salton, Inc.
P.O. Box 6916
Columbia, MO 65205-6916
1-800-233-9054
Email: Salton@Saltonusa.com

Limitation of Remedies: No representative or person is authorized to assume for Salton, Inc. any other liability in connection with the sale of our products. There shall be no claims for defects or failure of performance or product failure under any theory of tort, contract or commercial law including, but not limited to negligence, gross negligence, strict liability, breach of warranty and breach of contract. Repair, replacement or refund shall be the sole remedy of the purchaser under this warranty, and in no event shall Salton, Inc. be liable for any incidental or consequential damages, losses or expenses. Some states do not allow the exclusion or limitation of incidental or consequential damages, so the above limitation or exclusion may not apply to you.

Legal Rights: This warranty gives you specific legal rights, and you may also have other rights which vary from state to state.

For more information on Salton products Visit our website: www.esalton.com

© 2004 Salton, Inc.
All Rights Reserved

P/N 61575
Printed in China

